

Optimal Broadcast Scheduling for an Energy Harvesting Rechargeable Transmitter with a Finite Capacity Battery

Omur Ozel, *Student Member, IEEE*, Jing Yang, *Member, IEEE*, and Sennur Ulukus, *Member, IEEE*

Abstract—We consider the minimization of the transmission completion time with a battery limited energy harvesting transmitter in an M -user AWGN broadcast channel where the transmitter is able to harvest energy from the nature, using a finite storage capacity rechargeable battery. The harvested energy is modeled to arrive (be harvested) at the transmitter during the course of transmissions at arbitrary time instants. The transmitter has fixed number of packets for each receiver. Due to the finite battery capacity, energy may overflow without being utilized for data transmission. We derive the optimal offline transmission policy that minimizes the time by which all of the data packets are delivered to their respective destinations. We analyze the structural properties of the optimal transmission policy using a dual problem. We find the optimal total transmit power sequence by a directional water-filling algorithm. We prove that there exist $M - 1$ cut-off power levels such that user i is allocated the power between the $i - 1$ st and the i th cut-off power levels subject to the availability of the allocated total power level. Based on these properties, we propose an algorithm that gives the globally optimal offline policy. The proposed algorithm uses directional water-filling repetitively. Finally, we illustrate the optimal policy and compare its performance with several suboptimal policies under different settings.

Index Terms—Energy harvesting, rechargeable wireless networks, broadcast channels, finite-capacity battery, transmission completion time minimization, throughput maximization.

I. INTRODUCTION

ENERGY harvesting communication systems have been widely used in many wireless networking applications as they bring improved lifetime and ease of deployment. A distinctive characteristic of these systems is that energy becomes available for use in communication during the course of transmission of data. This requires the adaptation of the transmission policies to the energy arrivals. In this paper, we consider data transmission with an energy harvesting transmitter in a broadcast setting, and derive the optimal offline policy that achieves the minimum transmission completion time when the transmitter has a *finite capacity battery*.

Manuscript received May 2, 2011; revised October 8 and October 14, 2011, and February 24, 2012; accepted February 29, 2012. The associate editor coordinating the review of this paper and approving it for publication was L. Libman.

This work was supported by NSF Grants CCF 07-29127, CNS 09-64632, CCF 09-64645, and CCF 10-18185.

O. Ozel and S. Ulukus are with the Department of Electrical and Computer Engineering, University of Maryland, College Park, MD 20742 (e-mail: {omur, ulukus}@umd.edu).

J. Yang is with the Department of Electrical and Computer Engineering, University of Wisconsin-Madison, WI 53706, USA (e-mail: yangjing@ece.wisc.edu).

Digital Object Identifier 10.1109/TWC.2012.032812.110813

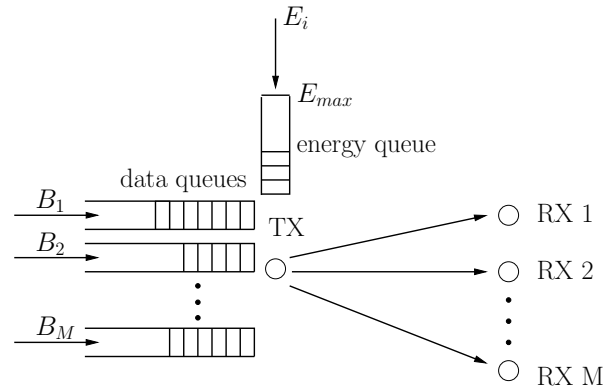

Fig. 1. Broadcasting (B_1, \dots, B_M) bits with an energy harvesting transmitter with a finite capacity battery.

As shown in Fig. 1, we consider a broadcast channel with an energy harvesting transmitter and M receivers. $M + 1$ queues at the transmitter are: M data queues that store the data destined to the receivers and an energy queue (battery) that stores the harvested energy. The energy queue has a finite capacity and can store at most E_{max} units of energy. As shown in Fig. 2, the energy arrives (is harvested) at times s_k in amounts E_k . E_0 is the initial energy available in the battery at time zero. Saving energy for future use is advantageous, however, finite battery capacity constrains this capability, and thus necessitates avoiding energy overflows. We focus on the optimal offline policy that minimizes the time, T , required to transmit B_m bits to receiver m , for $m = 1, \dots, M$. The transmission policy is subject to the causality of energy arrivals as well as the finite battery capacity constraint.

Data transmission in energy harvesting systems has attracted attention recently [1]–[10]. In [1], a back-pressure based scheduling scheme is shown to be average throughput optimal in the asymptotically large battery capacity regime. In [2], [3], stability optimal energy management policies are introduced for single and multi-user settings, together with some delay optimality properties. In [4], energy replenishment in sensor nodes is considered and the optimal online policy for controlling admissions into the data buffer is derived using dynamic programming.

Transmission completion time minimization problem in a point-to-point communication channel is solved in [5], [6] without battery constraints, and later in [7] with finite battery capacity constraints. In [8], we extend the analysis to the fading channel through a concise algorithm called *directional*

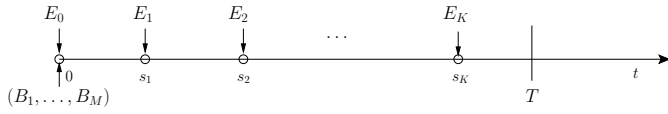

Fig. 2. Energies arrive at time instants s_k in amounts E_k .

water-filling. In [9], we solve the transmission completion time minimization problem in a broadcast channel, independently and concurrently with [10]. Both works assume that the transmitter battery size is unlimited. This paper extends these works to the case of a transmitter with a finite capacity battery.

Our work is closely connected with the recent literature on adaptive transmission for energy efficient and delay constrained data transmission [11]–[18]. In [11], [12], energy minimal packet scheduling under a deadline constraint is solved in a deterministic setting. Later, in [13], a calculus framework is developed for generalizing the approach in [11], [12] to address many different quality of service constraints. In [14], [15], energy management problems in communication satellites are solved under offline and online knowledge of the channel fade levels. In [16]–[18], delay optimal schedules over single and multi-user communication scenarios are found. In the current paper, we formulate a novel problem by combining the energy recharge model in [1]–[4] with the adaptive transmission model of [11]–[15] and solve for the optimal offline schedule for the quickest transmission of available data in an energy harvesting broadcast channel.

In [9], we show, under the assumption of an infinite sized battery, that the time sequence of the optimal total power in a broadcast channel increases monotonically as in the single-user case in [5], [6]. Moreover, in [9], we prove that there exists a *cut-off* power level for the power shares of the strong and weak users; strong user's power share is always less than or equal to this cut-off level and when it is strictly less than this cut-off level, weak user's power share is zero. The structure of the optimal policy in [9] is contingent upon the availability of an infinite capacity battery. In particular, when a large amount of energy is harvested, the development in [9] assumes that some portion of this harvested energy can always be saved for future use. However, when the battery capacity is finite, energy may overflow in such cases. Therefore, the added challenge in the finite capacity battery case is to accommodate every bit of the incoming energy by carefully managing the transmission power and users' power shares according to the times and amounts of the harvested energy.

We find, in the current paper, that as in [9], the determination of the total transmit power can be separated from the determination of the shares of the users without losing optimality. We first obtain the structural properties of the optimal policy by means of a dual problem, namely, the maximization of the region of bits served for the receivers by a fixed time T , i.e., the *maximum departure region*. We show that, similar to the battery unlimited case, we have a *cut-off* property in the optimal power shares. However, different from the battery unlimited case, the transmit power is not monotonically increasing.

We formulate the battery-unconstrained problem in [9] in

the rate domain. However, when there is a battery capacity constraint, the resulting no-energy-overflow constraint gives a non-convex constraint for the optimization problem in the rate domain. Therefore, we formulate the problem in the power domain in this paper. We show that the total power in each epoch must be the same as the total power in the single-user channel, which, in turn, can be found by the directional water-filling algorithm developed in [8]. We then find the optimal shares of the users from the total power in closed form via a single-variable optimization problem, completing the characterization of the optimal solution of the dual problem. We then use the structure of this dual problem, in particular the *cut-off* property and the optimality of directional water-filling to solve the transmission completion time minimization problem. Finally, we provide numerical illustrations and performance comparisons for the optimal offline policy.

II. SYSTEM MODEL AND PROBLEM FORMULATION

As shown in Figs. 1 and 2, the transmitter has M data queues each having B_m bits destined to the m th receiver, and an energy queue of finite capacity E_{max} . The initial energy available in the battery at time zero is E_0 and energy arrivals occur at times $\{s_1, s_2, \dots\}$ in amounts $\{E_1, E_2, \dots\}$. We call the time interval between two consecutive energy arrivals an *epoch*. The epoch lengths are $\ell_i = s_i - s_{i-1}$ with $s_0 = 0$. A standing assumption in the paper is $E_i \leq E_{max}$ for all i , as otherwise the excess energy $E_i - E_{max}$ cannot be stored in the battery anyway.

The physical layer is modeled as an AWGN broadcast channel, with received signals

$$Y_m = X + Z_m, \quad m = 1, \dots, M \quad (1)$$

where X is the transmit signal, and Z_m is a Gaussian noise with zero-mean and variance σ_m^2 , and without loss of generality $\sigma_1^2 \leq \sigma_2^2 \leq \dots \leq \sigma_M^2$. Therefore, the first user is the strongest and the M th user is the weakest user in our broadcast channel. The capacity region for the M -user AWGN broadcast channel is the set of rate vectors (r_1, \dots, r_M) [19]:

$$r_m = \frac{1}{2} \log_2 \left(1 + \frac{\alpha_m P}{\sum_{j < m} \alpha_j P + \sigma_m^2} \right), \quad m = 1, \dots, M \quad (2)$$

where $\alpha_m \geq 0$ and $\sum_m \alpha_m = 1$.

Our goal is to select a transmission policy that minimizes the time, T , by which all of the bits are delivered to their intended receivers. The transmitter adapts its transmit power and the portions of the total transmit power used to transmit signals to the M users according to the available energy level and the remaining number of bits. The energy consumed must satisfy the causality constraints, i.e., at any given time t , the total amount of energy consumed up to time t must be less than or equal to the total amount of energy harvested up to time t .

Let us denote the transmit power at time t as $P(t)$ for $t \in [0, T]$. The transmission policy in a broadcast channel is comprised of the total power $P(t)$ and the portion of the total transmit power $\alpha_m(t)$ that is allocated for user m , $m = 1, \dots, M$. As $\sum_{m=1}^M \alpha_m(t) = 1$, the transmission policy is

represented by $\alpha_m(t)$, $m = 1, \dots, M - 1$ and $\alpha_M(t) = 1 - \sum_{m=1}^{M-1} \alpha_m(t)$. For the special case of $M = 2$, we denote the strong user's power share without a subscript as $\alpha(t)$.

The total energy consumed by the transmitter up to time t can be expressed as $\int_0^t P(\tau) d\tau$. Note that because of the finite battery capacity constraint, at any time t , if the unconsumed energy is greater than E_{max} , only E_{max} can be stored in the battery and the rest of the energy overflows and hence is wasted. This may happen only at the instants of energy arrival. Therefore, the total removed energy from the battery at s_k , $E_r(s_k)$, including the consumed part and the wasted part, can be expressed recursively for $k = 1, 2, \dots$ as

$$E_r(s_k^+) = \max \left\{ E_r(s_{k-1}^+) + \int_{s_{k-1}}^{s_k} P(\tau) d\tau, \left(\sum_{j=0}^k E_j - E_{max} \right)^+ \right\} \quad (3)$$

where $(x)^+ = \max\{0, x\}$, and s_k^+ should be interpreted as $s_k + \epsilon$ for arbitrarily small $\epsilon > 0$. In addition, $E_r(s_0) = 0$. We can extend the definition of E_r for the times $t \neq s_k$ as:

$$E_r(t) = E_r(s_{h_+(t)}^+) + \int_{s_{h_+(t)}}^t P(\tau) d\tau \quad (4)$$

where $h_+(t) = \max\{i : s_i \leq t\}$. As the transmitter cannot utilize the energy that has not arrived yet, the transmission policy is subject to an energy causality constraint. The removed energy $E_r(t)$ cannot exceed the total energy arrival during the communication. This constraint is mathematically stated as follows:

$$E_r(t) \leq \sum_{i=0}^{h_-(t)} E_i, \quad \forall t \in [0, T] \quad (5)$$

where $h_-(t) = \max\{i : s_i < t\}$. As the energies arrive at discrete times, the causality constraint reduces to inequalities that have to be satisfied at the times of energy arrivals:

$$E_r(s_{k-1}^+) + \int_{s_{k-1}}^{s_k} P(\tau) d\tau \leq \sum_{i=0}^{k-1} E_i, \quad \forall k \quad (6)$$

An illustration of $E_r(t)$ and the causality constraint is shown in Fig. 3. The upper curve in Fig. 3 represents the total energy arrived and the lower curve is obtained by subtracting E_{max} from the upper curve. The causality constraint imposes $E_r(t)$ to remain below the upper curve. Moreover, $E_r(t)$ always remains above the lower curve by definitions in (3) and (4). Therefore, $E_r(t)$ always lies in between these two curves. In the particular $E_r(t)$ shown in Fig. 3, the energy in the battery exceeds E_{max} at the time of the third energy arrival at s_3 and some energy is removed from the battery without being utilized for data transmission. After s_3 , energy removal from the battery continues due to data transmission and hence the removal curve approaches the total energy arrival curve indicating that the battery energy is decreasing.

As observed in Fig. 3, some energy is lost due to energy overflow if $E_r(t)$ intersects the lower curve at the vertically rising parts at the energy arrival instants. Therefore, a transmission policy guarantees no-energy-overflow if the following

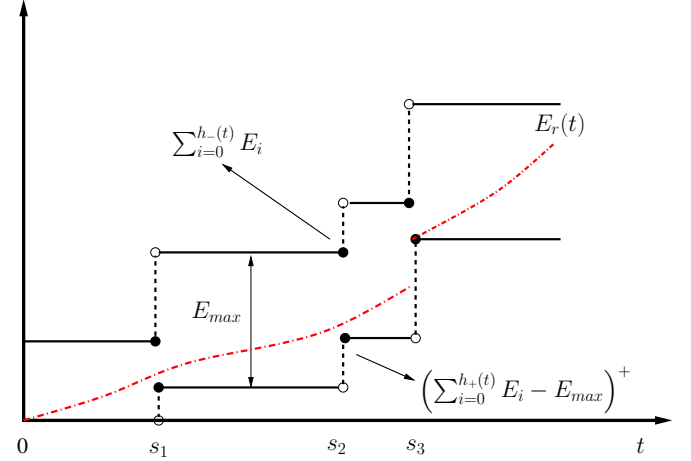

Fig. 3. The total removed energy curve $E_r(t)$. The jump at s_3 represents an energy overflow because of the finite battery capacity limit.

constraint is satisfied:

$$\int_0^t P(\tau) d\tau \geq \left(\sum_{i=0}^{h_+(t)} E_i - E_{max} \right)^+, \quad \forall t \in [0, T] \quad (7)$$

The constraint in (7) imposes that at least $\sum_{i=0}^k E_i - E_{max}$ amount of energy has been consumed by the time the k th energy arrives so that the battery can accommodate E_k at time s_k . If a policy satisfies (7), the max in (3) always yields the first term in it. Therefore, the causality constraint in (6) is simplified to the following:

$$\int_0^t P(\tau) d\tau \leq \sum_{i=0}^{h_-(t)} E_i, \quad \forall t \in [0, T] \quad (8)$$

This is depicted in Fig. 4 in which the total energy curve of the policy does not intersect the lower curve at the vertically rising parts (at the energy arrival instants) and thus no energy is removed from the battery due to energy overflows. Hence, the causality constraint reduces to the condition that the total energy arrival curve must lie below the upper curve in Fig. 4.

Instead of directly finding the optimal policy that minimizes the transmission completion time, we start by solving the dual problem of finding the *maximum departure region*, the largest region of number of bits that the transmitter can deliver to each user by a fixed time T . Solving the dual problem enables us to identify the properties of an optimal policy in the original problem.

III. THE DUAL PROBLEM

In this section, we consider the dual problem of determining the *maximum departure region* which is the set of number of bits that can be delivered to the receivers by a fixed deadline T .

Definition 1 For any fixed transmission duration T , the *maximum departure region*, denoted as $\mathcal{D}(T)$, is the union of $\mathcal{R}(B_1, \dots, B_M) = \{(b_1, \dots, b_M) : 0 \leq b_1 \leq B_1; \dots; 0 \leq b_M \leq B_M\}$ where (B_1, \dots, B_M) is the total number of bits sent by some power allocation policy $P(t)$ and $\alpha_m(t)$,

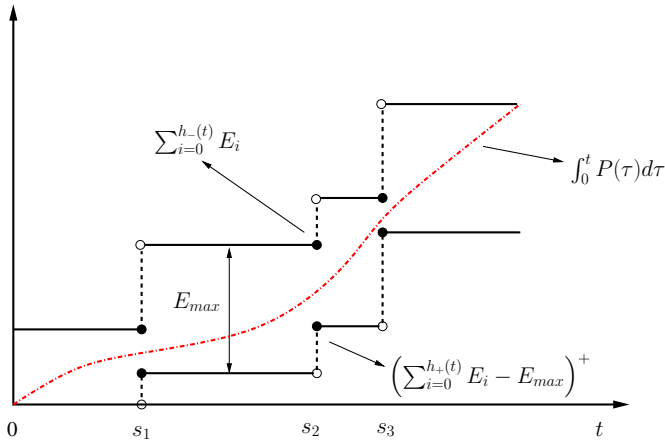

Fig. 4. Energy causality constraint and no-energy-overflow constraint are depicted as cumulative energy curves and the power consumption curve of a transmission policy simultaneously satisfy these two constraints by lying in between these two curves.

$m = 1, \dots, M$, that satisfy the energy causality (8) and no-energy-overflow (7) conditions.

The departure region of any policy that causes energy overflows can be dominated by a policy that does not allow energy overflows. Hence, in the definition of $\mathcal{D}(T)$, we restrict the policies to satisfy the no-energy-overflow condition in (7). We refer to any policy that satisfies the energy causality and no-energy-overflow conditions as *feasible*. We call a feasible policy *optimal* if it achieves the boundary of $\mathcal{D}(T)$.

The transmission rates remain constant between energy harvests under any optimal policy (c.f. Lemma 1 in [9] and Lemma 2 in [5], [6]). Therefore, in the sequel, we restrict ourselves to the policies in which the powers and the power shares remain constant between any two consecutive energy arrivals. Let K denote the number of energy arrivals in $(0, T)$ yielding $K + 1$ epochs, with $s_0 = 0$ and $s_{K+1} = T$. We represent the transmission policy by $(M+1)(K+1)$ variables P_k and α_{mk} , for $m = 1, \dots, M$, and $k = 1, \dots, K + 1$. P_k and α_{mk} denote, respectively, the total power allocated and the corresponding power share of user m over the duration $[s_{k-1}, s_k)$. The causality constraint in (8) reduces to the following constraints on P_i :

$$\sum_{i=1}^k P_i \ell_i \leq \sum_{i=0}^{k-1} E_i, \quad k = 1, \dots, K + 1 \quad (9)$$

and the no-energy-overflow condition in (7) reduces to:

$$\sum_{i=1}^k P_i \ell_i \geq \left(\sum_{i=0}^k E_i - E_{max} \right)^+, \quad k = 1, \dots, K \quad (10)$$

An important property of $\mathcal{D}(T)$ is stated next [20].

Lemma 1 $\mathcal{D}(T)$ is a convex region.

Since $\mathcal{D}(T)$ is a convex region¹ its boundary is uniquely characterized by the supporting hyperplanes [21]. Therefore,

¹In fact, it is a strictly convex region due to the strict concavity of the log function. In a strictly convex region, no two points on the boundary of $\mathcal{D}(T)$ lie on the same hyperplane.

in order to characterize the boundary of $\mathcal{D}(T)$, we consider all possible supporting hyperplanes to the maximum departure region and solve the following optimization problem for all $\mu_1, \dots, \mu_M \geq 0$,

$$\begin{aligned} \max_{\{P_i, \alpha_i\}} & \mu_1 \sum_{i=1}^{K+1} r_1(\alpha_i, P_i) \ell_i + \dots + \mu_M \sum_{i=1}^{K+1} r_M(\alpha_i, P_i) \ell_i \\ \text{s.t.} & \sum_{i=1}^k P_i \ell_i \leq \sum_{i=0}^{k-1} E_i, \quad k = 1, \dots, K + 1 \\ & \sum_{i=1}^k P_i \ell_i \geq \left(\sum_{i=0}^k E_i - E_{max} \right)^+, \quad k = 1, \dots, K \end{aligned} \quad (11)$$

where $\mu_1, \dots, \mu_M \geq 0$ are the weights of the number of departed bits, and $r_m(\alpha_i, P_i)$ is the rate allocated for the m th user at epoch i :

$$r_m(\alpha_i, P_i) = \frac{1}{2} \log_2 \left(1 + \frac{\alpha_{mi} P_i}{\sum_{j < m} \alpha_{ji} P_j + \sigma_m^2} \right) \quad (12)$$

Therefore, $\sum_{i=1}^{K+1} r_m(\alpha_i, P_i) \ell_i$ is the total number of bits served for user m in the $[0, T]$ interval.

The problem in (11) is not a convex problem as the variables α_{mi} and P_i appear in a product form, causing the objective function to be a non-concave function of the variables α_i and P_i . Even though the objective function is concave with respect to P_i for any given α_i , since the optimal α_i s depend on the powers, we cannot immediately conclude that the objective function is concave in powers. We solve (11) in two steps. We first optimize (11) with respect to α_i for a given fixed set of powers. We show that when optimal α_i s, which are functions of the powers, are inserted back into (11), we obtain an objective function which is concave in powers, and this leads to a convex overall problem. In [20], we solved the problem in (11) for $M = 2$ in the rate domain. The difficulty of working in the rate domain is that the feasible set of the problem becomes non-convex under the constraints due to finite capacity battery; see the discussion around [20, eqn. (24)]. We overcome this issue here by casting the problem in terms of powers.

Assume that P_i are given at each epoch i . We solve the following problem in each epoch i :

$$\max_{\alpha_i} \mu_1 r_1(\alpha_i, P_i) + \dots + \mu_M r_M(\alpha_i, P_i) \quad (13)$$

Let us define the result of the optimization problem in (13) as a function of P :

$$f(P) \triangleq \max_{\alpha} \mu_1 r_1(\alpha, P) + \dots + \mu_M r_M(\alpha, P) \quad (14)$$

We have the following lemma whose proof is provided in Appendix A.

Lemma 2 $f(P)$ is a strictly concave function of P and the derivative of $f(P)$ is continuous.

Then, the problem in (11) can be written as a problem only in terms of P_i as follows:

$$\begin{aligned} \max_{\mathbf{P}} \quad & \sum_{i=1}^{K+1} f(P_i) \ell_i \\ \text{s.t.} \quad & \sum_{i=1}^k P_i \ell_i \leq \sum_{i=0}^{k-1} E_i, \quad k = 1, \dots, K+1 \\ & \sum_{i=1}^k P_i \ell_i \geq \left(\sum_{i=0}^k E_i - E_{max} \right)^+, \quad k = 1, \dots, K \end{aligned} \quad (15)$$

The problem in (15) is a convex optimization problem. The objective function is strictly concave by Lemma 2 and the feasible set is a convex set. In the next lemma, we state a key structural property of the optimal policy. The proof is provided in Appendix B.

Lemma 3 *Optimal total transmit power sequence P_i^* , $i = 1, \dots, K+1$, is independent of the values of μ_1, \dots, μ_M . In particular, it is the same as the single-user optimal transmit power sequence, i.e., it is the same as the solution for $\mu_1 > 0$ and $\mu_m = 0$, $m = 2, \dots, M$.*

Therefore, irrespective of the values of μ_1, \dots, μ_M , the unique total power allocation can be found by the directional water-filling algorithm introduced in [8]. An alternative algorithm for solving the same problem is provided in [7], which uses the feasible energy tunnel approach. The structures of the two alternative algorithms in [7], [8], as well as the one in [5], [6] for the unconstrained battery case, are determined only by the strict concavity of the rate-power relation. We obtained the same structure in the broadcast channel here due to the strict concavity of $f(P)$ in P , which is stated and proved in Lemma 2.

Once the optimal *total* transmit powers, P_i^* , are determined, the optimal power shares of the users can be determined by solving the problem in (13) in terms of α_i , by using the analysis presented in the proof of Lemma 2 in Appendix A. In particular, splitting the total power among M users requires a *cut-off* power structure. Whenever $\mu_j \leq \mu_l$ for any $1 \leq l < j \leq M$, i.e., whenever a degraded user has a smaller weight, the solution of (13) is such that $r_{ji}^* = 0$ for any value of P_i . This is because, the allocated rate of a degraded user j can be transferred to a stronger user l [19], and doing so yields a higher weighted sum of rates if $\mu_j < \mu_l$ (see also Appendix A). Hence, we remove the users j where $\mu_j \leq \mu_l$ and $1 \leq l < j \leq M$. The remaining $R \leq M$ users are such that $\sigma_1^2 \leq \sigma_2^2 \leq \dots \leq \sigma_R^2$ with $\mu_1 < \mu_2 < \dots < \mu_R$. Using a first order differential analysis (see Appendix A), the optimal cut-off power levels for the remaining R users must satisfy the following equations for $m = 1, \dots, R-1$:

$$P_{cm} = \max \left\{ \left(\frac{\mu_m \sigma_{\bar{m}}^2 - \mu_{\bar{m}} \sigma_m^2}{\mu_{\bar{m}} - \mu_m} \right)^+, P_{c(m-1)} \right\} \quad (16)$$

where \bar{m} is the smallest user index with $P_{c\bar{m}} > P_{cm}$. By convention, we have $P_{c0} = 0$, $P_{cR} = \infty$. We note that P_{cm} and \bar{m} in (16) can be recursively calculated. We immediately

observe that for $m = R-1$, $\bar{m} = R$ and $P_{cm} = P_{c(R-1)}$ for $m = u_1^*, \dots, R-1$ where:

$$P_{c(R-1)} = \max_{k \in [1:R-1]} \left(\frac{\mu_k \sigma_R^2 - \mu_R \sigma_k^2}{\mu_R - \mu_k} \right)^+ \quad (17)$$

$$u_1^* = \arg \max_{k \in [1:R-1]} \left(\frac{\mu_k \sigma_R^2 - \mu_R \sigma_k^2}{\mu_R - \mu_k} \right)^+ \quad (18)$$

Similarly, we find P_{cm} for $m = u_1^* - 1$ by replacing R with u_1^* in (17). $P_{cm} = P_{c(u_1^*-1)}$ and $\bar{m} = u_1^*$ for $m = u_2^*, \dots, u_1^* - 1$ where u_2^* is calculated as in (18) by replacing R with u_1^* . We continue until we reach $u_j^* = 1$ for some j . We can verify that P_{cm} calculated this way satisfies the conditions in (16); therefore, this procedure determines the desired cut-off power levels.

We show the structure of optimally splitting the total power among the users in Fig. 5. The top portion of the total power is allocated to the user with the worst channel and the power below it is interference for this user. The bottom portion of the total power is allocated to the user with the best channel and this user experiences no interference. We note that the cut-off power levels are independent of the varying total power levels in epochs or the E_{max} constraint.

As a specific example, for the two-user case ($M = 2$), the single cut-off power level is

$$P_c = \left(\frac{\mu_1 \sigma_2^2 - \mu_2 \sigma_1^2}{\mu_2 - \mu_1} \right)^+ \quad (19)$$

If the optimal total power level in the i th epoch, P_i^* , is smaller than the cut-off power level P_c , then only the stronger user's data is transmitted. If $P_i^* \geq P_c$, then the strong user's power share is P_c and the weak user's power share is the remainder of the power in that epoch. From Lemma 3, the optimal policies that achieve the boundary of $\mathcal{D}(T)$ have a common *total* transmit power and from Lemma 2 its splitting between the two users depends on μ_1, μ_2 through μ_2/μ_1 as reflected in the cut-off power in (19). For different values of μ_1, μ_2 , the optimal policy achieves different boundary points on $\mathcal{D}(T)$. Varying the values of μ_1, μ_2 traces the boundary of $\mathcal{D}(T)$.

IV. MINIMUM TRANSMISSION COMPLETION TIME FOR GIVEN (B_1, \dots, B_M)

In this section, our goal is to minimize the transmission completion time given (B_1, \dots, B_M) :

$$\begin{aligned} \min_{\mathbf{P}} \quad & T \\ \text{s.t.} \quad & \sum_{i=1}^k P_i \ell_i \leq \sum_{i=1}^{k-1} E_i, \quad k = 1, \dots, K+1 \\ & \sum_{i=1}^k P_i \ell_i \geq \left(\sum_{i=0}^k E_i - E_{max} \right)^+, \quad k = 1, \dots, K \\ & \sum_{i=1}^{K+1} \frac{1}{2} \log_2 \left(1 + \frac{\alpha_m^*(P_i) P_i}{\sum_{j < m} \alpha_j^*(P_i) P_i + \sigma_m^2} \right) \ell_i = B_m, \quad \forall m \end{aligned} \quad (20)$$

where $K = K(T)$ is the number of energy arrivals over $(0, T)$, and $l_{K(T)+1} = T - s_{K(T)}$. Since $K(T)$ depends on T , the optimization problem in (20) is not convex in general.

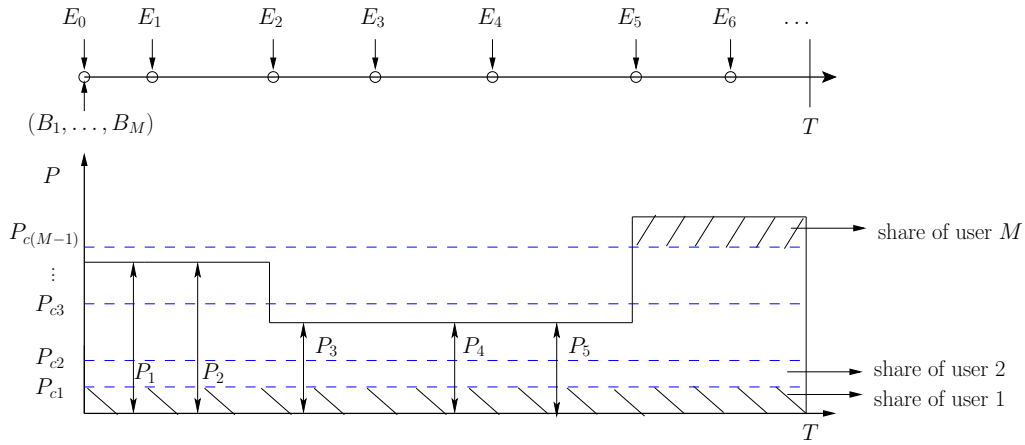

Fig. 5. Optimally splitting the total power for M users.

We observe that (20) is the dual problem of finding the maximum departure region for fixed T in (11) in the sense that, if the minimum transmission completion time for (B_1, \dots, B_M) is T , then (B_1, \dots, B_M) must lie on the boundary of $\mathcal{D}(T)$, and the optimal policies in both problems must be the same. In the following, we provide an algorithm to minimize the transmission completion time for given (B_1, \dots, B_M) , by using the properties we developed for the optimal policy for the dual problem in the previous section. We first start with the $M = 2$ user case.

(B_1, B_2) must lie on the boundary of $\mathcal{D}(T_{min})$. Hence, without losing optimality we restrict our attention to the policies which allocate the total transmit power by directional water-filling and have the cut-off power structure. As the initial step, we suppose that the transmitter transmits only to the stronger user with an arbitrary P_c and find the transmission completion time for the stronger user by $T_1 = \frac{B_1}{\frac{1}{2} \log_2(1+P_c)}$. For this fixed T_1 , we run the directional water-filling algorithm and find the total power allocation $P_1, P_2, \dots, P_{K(T_1)+1}$ with the deadline T_1 . The number of bits transmitted to the stronger user is

$$D_1(T_1, P_c) = \sum_{i=1}^{K(T_1)+1} \frac{1}{2} \log_2 (1 + P_i - [P_i - P_c]^+) \ell_i \quad (21)$$

We allocate the remaining power $[P_i - P_c]^+$ to the weaker user and calculate the total bits departed from the weaker user's queue by deadline T_1 as

$$D_2(T_1, P_c) = \sum_{i=1}^{K(T_1)+1} \frac{1}{2} \log_2 \left(1 + \frac{[P_i - P_c]^+}{P_c + \sigma^2} \right) \ell_i \quad (22)$$

$D_2(T_1, P_c)$ is monotonically decreasing with P_c for fixed T_1 . In fact, $D_2(T_1, P_c)$ takes its maximum value at $P_c = 0$ and as P_c is increased, the achievable bit departure pairs travel on the boundary of $\mathcal{D}(T_1)$ from one extreme to the other.

We divide the bit departure plane into 5 regions as shown in Fig. 6. The regions are bordered by the constant B_1, B_2 lines and the $\mathcal{D}(T_{min})$ curve. Region ① is $D_1 \leq B_1$ and $D_2 \leq B_2$. Regions ② and ③ combined represent the northwest part, i.e., $D_1 \leq B_1$ and $D_2 \geq B_2$. The border between regions 2 and 3 is the $\mathcal{D}(T_{min})$ curve. Region ⑤ is bordered

by the constant B_1 line and the $\mathcal{D}(T_{min})$ curve. The rest of the first quadrant is region ④. We start the problem with the knowledge of (B_1, B_2) . While we know that (B_1, B_2) must lie on the boundary of $\mathcal{D}(T_{min})$, we do not know $\mathcal{D}(T_{min})$ or T_{min} . We want to find T_{min} and the policy that achieves it.

After the initial step, we have $D_1(T_1, P_c) \leq B_1$ since $P_i < P_c$ may occur in some epochs. Hence, the initial operating point lies in one of regions ①, ②, ③. If the operating point lies in the interior of region ①, it implies that (B_1, B_2) transmission cannot be completed by T_1 . Therefore, we decrease P_c , obtain $T_1 = \frac{B_1}{\frac{1}{2} \log_2(1+P_c)}$, and repeat the procedure, until we leave this region. If the operating point hits the B_1 line, i.e., $D_1\left(\frac{B_1}{\frac{1}{2} \log_2(1+P_c)}, P_c\right) = B_1$, while $D_2\left(\frac{B_1}{\frac{1}{2} \log_2(1+P_c)}, P_c\right) < B_2$, as shown in Fig. 6(a), then $P_c < P_i$ for all epochs i . Even if we further decrease P_c to increase D_2 , we always have $D_1\left(\frac{B_1}{\frac{1}{2} \log_2(1+P_c)}, P_c\right) = B_1$ in view of the update rule of T_1 as $T_1 = \frac{B_1}{\frac{1}{2} \log_2(1+P_c)}$. Hence, similar to the algorithm for the unlimited battery case in [9], we apply bisection only on P_c and approach $D_2\left(\frac{B_1}{\frac{1}{2} \log_2(1+P_c)}, P_c\right) = B_2$ sufficiently. For the final value of P_c , $T_{min} = \frac{B_1}{\frac{1}{2} \log_2(1+P_c)}$.

Then, we consider the scenario when the operating point enters into region ② or ③, i.e., $D_2\left(\frac{B_1}{\frac{1}{2} \log_2(1+P_c)}, P_c\right) > B_2$ while $D_1\left(\frac{B_1}{\frac{1}{2} \log_2(1+P_c)}, P_c\right) \leq B_1$. For this scenario, we fix T_1 and increase P_c such that $D_2(T_1, P_c) = B_2$. This brings us to the horizontal B_2 line, as shown in Fig. 6(b). Depending on the updated D_1 under this policy, the operating point lies either on the left or on the right of the (B_1, B_2) point. If we end up at $D_1(T_1, P_c) < B_1$, then $T_1 < T_{min}$. We decrease P_c , and set $T_1 = \frac{B_1}{\frac{1}{2} \log_2(1+P_c)}$. Another round of directional water-filing results $D_2 > B_2$, and brings the operating point back into region ② and ③. If we end up at $D_1(T_1, P_c) > B_1$, it implies $T_1 > T_{min}$. Then, we fix P_c and decrease T_1 only. By doing this, we decrease D_1 and D_2 at the same time and this brings the operating point back to the horizontal B_2 line, which in turn brings us back to one of the previously considered cases depending on whether $D_1(T_1, P_c)$ is greater or smaller than B_1 .

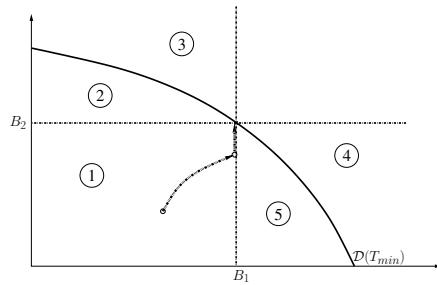

(a) If the algorithm starts in region ① and hits $D_1(T_1, P_c) = B_1$, then the trajectory does not deviate from the constant B_1 line.

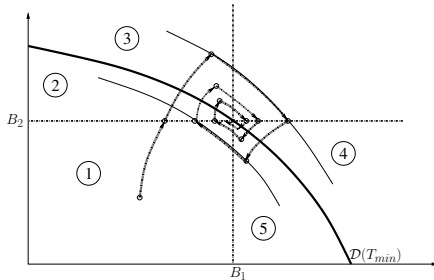

(b) If $D_1(T_1, P_c) < B_1$ and $D_2(T_1, P_c) = B_2$ is achieved, then a bisection algorithm converges to the desired (B_1, B_2) point yielding the minimum T .

Fig. 6. The possible trajectories followed during the operation of the algorithm.

For all of the above cases, we carefully control the step size when we do the adjustment of P_c and T_1 , to make sure that the operating point gets closer to the (B_1, B_2) point at each step. In particular, we update T and P_c using a bisection method. Starting with arbitrary step sizes, we halve the step size each time the update sign is changed, i.e., if an increase is required while previous update was a decrease, then step size is halved. Convergence is guaranteed due to monotonicity and continuity of $D_1(T_1, P_c)$ and $D_2(T_1, P_c)$ [22].

The algorithm naturally generalizes for an M -user broadcast channel. Initially, we suppose that the transmitter transmits only to user 1 with an arbitrary P_{c1} and find the transmission completion time for the strongest user by $T_1 = \frac{B_1}{\frac{1}{2} \log_2(1+P_{c1})}$. For this fixed T_1 , we run the directional water-filling algorithm and find the total power allocation $P_1, P_2, \dots, P_{K(T_1)+1}$ with the deadline T_1 . The number of bits transmitted to user 1 is $D_1(T_1, P_{c1})$. We allocate the remaining power $[P_i - P_{c1}]^+$ to the second user and calculate the total bits departed from the second user's queue by deadline T_1 , $D_2(T_1, P_{c1})$, as in (22). If $D_2(T_1, P_{c1}) > B_2$, then B_2 bits can be served for user 2. We find the corresponding cut-off power level P_{c2} . We continue finding the remaining cut-off power levels P_{cm} until some power level becomes infeasible, i.e., some user cannot be served by T_1 . In this case, we decrease P_{c1} and recalculate T_1 . Otherwise, (B_2, \dots, B_M) bits can be served by T_1 . In this case, we fix T_1 and increase P_{c1} . We apply the bisection method and update the step sizes according to whether an increase or decrease is required and whether previous update was an increase or a decrease. The convergence is again guaranteed due to the monotonicity and continuity of the number of bits served for each user [22].

V. NUMERICAL RESULTS

We consider a band-limited AWGN broadcast channel with $M = 3$ users. The bandwidth is $B_W = 1$ MHz and the noise power spectral density is $N_0 = 10^{-19}$ W/Hz. We assume that the path losses between the transmitter and the receivers are 100 dB, 105 dB and 110 dB.

$$\begin{aligned} r_1 &= B_W \log_2 \left(1 + \frac{\alpha_1 P h_1}{N_0 B_W} \right) \\ &= \log_2 \left(1 + \frac{\alpha_1 P}{10^{-3}} \right) \text{ Mbps} \end{aligned} \quad (23)$$

$$\begin{aligned} r_2 &= B_W \log_2 \left(1 + \frac{\alpha_2 P h_2}{\alpha_1 P h_2 + N_0 B_W} \right) \\ &= \log_2 \left(1 + \frac{\alpha_2 P}{\alpha_1 P + 10^{-2.5}} \right) \text{ Mbps} \end{aligned} \quad (24)$$

$$\begin{aligned} r_3 &= B_W \log_2 \left(1 + \frac{(1 - \alpha_1 - \alpha_2) P h_3}{(\alpha_1 + \alpha_2) P h_3 + N_0 B_W} \right) \\ &= \log_2 \left(1 + \frac{(1 - \alpha_1 - \alpha_2) P}{(\alpha_1 + \alpha_2) P + 10^{-2}} \right) \text{ Mbps} \end{aligned} \quad (25)$$

A. Deterministic Energy Arrivals

In this subsection, we illustrate the optimal offline policy in a deterministic energy arrival sequence setting. In particular, we assume that at times $\mathbf{t} = [0, 2, 5, 8, 9, 12]$ s, energies with the amounts $\mathbf{E} = [8, 3, 6, 9, 8, 9]$ mJ are harvested. The battery capacity is $E_{max} = 10$ mJ.

We first study the two-user broadcast channel by removing the third user, i.e., setting $B_3 = 0$. We find the maximum departure region of the two-user broadcast channel $\mathcal{D}(T)$ for $T = 10, 12, 13, 14, 16$ s, and plot them in Fig. 7. These regions are obtained by first finding the total power sequence and then varying the cut-off power level P_c . In particular, $P_c = 0$ implies all the power is allocated to user 2 while $P_c = \max_i P_i$ implies that all the power is allocated to user 1. Note that the maximum departure regions are strictly convex for all T and monotone in T . We observe that the gap between the regions for different T increases in the passage from $T = 12$ s to $T = 13$ s since an energy arrival occurs at $t = 12$ s.

We next consider the same energy arrival sequence with $(B_1, B_2) = (22, 3)$ Mbits. We have the optimal transmission policy as shown in Fig. 8. Initial energy in the battery and the first two energy arrivals are spread till $t = 8$ s. However, only 2 mJ energy can flow from the time interval $[8, 9]$ to $[9, 12]$ as $E_{max} = 10$ mJ constrains the energy flow. This, in turn, breaks the monotonicity in the total transmit power. In the optimal policy, $P_c = 2.15$ mW is found, while in the first three epochs the transmit power is allocated as 2.125 mW. Therefore, only the stronger user's data is transmitted in the first three epochs. In the remaining epochs, both users' data are transmitted simultaneously with transmit power $P_4 = 7$ mW in $[8, 9]$ s, $P_5 = 3.33$ mW in $[9, 12]$ s and $P_6 = 6.66$ mW in $[12, 13.35]$ s. Note that $(22, 3)$ Mbits point (marked with *) in Fig. 7 is not included in $\mathcal{D}(T)$ at $T = 13$ s while it is strictly included in $\mathcal{D}(T)$ at $T = 14$ s.

Finally, we consider the same energy arrival sequence with $(B_1, B_2, B_3) = (15, 4, 1.75)$ Mbits and the optimal policy is shown in Fig. 9. In the optimal total power sequence, 2 mJ energy is transferred from $[8, 9]$ s to $[9, 12]$ s and about 1 mJ of

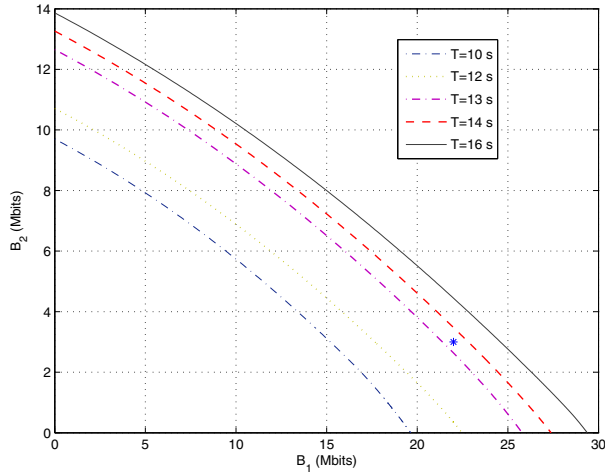

Fig. 7. The maximum departure region $\mathcal{D}(T)$ for different T .

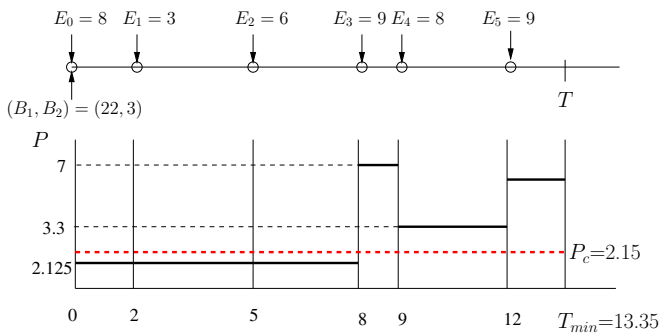

Fig. 8. Cut-off power $P_c = 2.15$ mW. Optimal transmit rates $\mathbf{r}_1 = [1.6438, 1.6554, 1.6554, 1.6554]$ Mbps and $\mathbf{r}_2 = [0, 0.9358, 0.2827, 0.8877]$ Mbps, with durations $\mathbf{l} = [8, 1, 3, 1.35]$ s.

this transferred energy is further transferred to the last epoch. We calculate the cut-off power levels as $P_{c1} = 0.97$ mW and $P_{c2} = 1.79$ mW. The bits of all three users are always transmitted throughout the communication. The transmission is finished by $T = 15.33$ s.

B. Stochastic Energy Arrivals

In this subsection, we consider stochastic energy arrivals in the two-user case, i.e., we set $B_3 = 0$. We compare the performance of the optimal offline policy with those of three suboptimal policies which require no offline knowledge of the energy arrivals.

1) *Constant Power Constant Share (CPCS) Policy*: This policy transmits with constant power equal to the average recharge rate, $P = \mathbb{E}[E]$, whenever the battery energy is non-zero and the transmitter is silent otherwise. If the battery energy exceeds E_{max} at the energy arrival instants, then excess energy overflows. In addition, the strong user's power share is constant whenever the transmitter is non-silent. In particular,

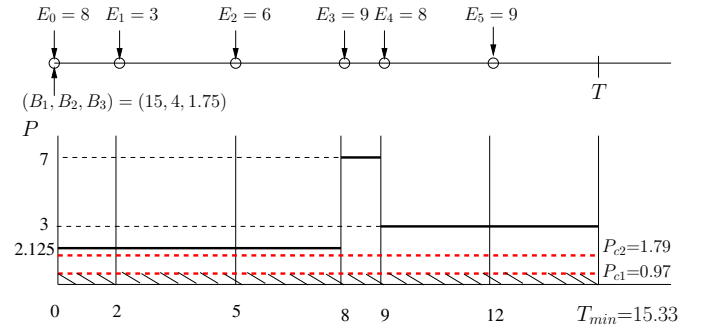

Fig. 9. Cut-off power levels $P_{c1} = 0.97$ mW and $P_{c2} = 1.79$ mW. Optimal transmit rates $\mathbf{r}_1 = [0.9783, 0.9783, 0.9783]$ Mbps, $\mathbf{r}_2 = [0.2610, 0.2610, 0.2610]$ Mbps and $\mathbf{r}_3 = [0.4040, 0.5280, 0.1409]$ Mbps with durations $\mathbf{l} = [8, 1, 6.33]$ s.

the constant power share α^* is found from:

$$\frac{B_1}{B_2} = \frac{\log_2 \left(1 + \frac{\alpha \mathbb{E}[E]}{\sigma_1^2} \right)}{\log_2 \left(1 + \frac{(1-\alpha) \mathbb{E}[E]}{\alpha \mathbb{E}[E] + \sigma_2^2} \right)} \quad (26)$$

Note that CPCS does not require offline or online knowledge of the energy arrivals. It only requires the mean of the energy arrival process, $\mathbb{E}[E]$.

2) *Energy Adaptive Power Constant Share (EACS) Policy*: This policy transmits with power equal to the instantaneous energy value at each energy arrival instant, $P_i = E_{current}$. If the battery energy exceeds E_{max} at the energy arrival instants, then excess energy overflows. Moreover, the power share of the stronger user is set constant equal to that found in (26) throughout the duration in which the transmitter is not silent and both users' data queues are non-empty. Whenever one data queue becomes empty, no power is allocated for that user.

3) *Energy Adaptive Power Dynamic Share (EADS) Policy*: This policy transmits with power equal to the instantaneous energy value at each energy arrival instant, $P_i = E_{current}$. If the battery energy exceeds E_{max} at the energy arrival instants, then excess energy overflows. The strong user's power share α_i^* is updated dynamically whenever an energy arrival occurs according to:

$$\frac{B_{1i}}{B_{2i}} = \frac{\log_2 \left(1 + \frac{\alpha_i P_i}{\sigma_1^2} \right)}{\log_2 \left(1 + \frac{(1-\alpha_i) P_i}{\alpha_i P_i + \sigma_2^2} \right)} \quad (27)$$

where B_{1i} and B_{2i} are the number of bits of user 1 and user 2, respectively, at the beginning of epoch i . Note that EADS requires online knowledge of the energy arrival process as well as the remaining data backlog.

In the simulations, we consider a compound Poisson energy arrival process. The average inter-arrival time is 1 s and the arriving energy is a random variable which is distributed uniformly in $[0, 2P_{avg}]$ mJ, where $P_{avg} \leq \frac{E_{max}}{2}$ is the average recharge rate. The performance metric of the policies is the average transmission completion time over 1000 realizations of the stochastic energy arrival process. We first set the $\rho = \frac{B_1}{B_2}$ ratio constant, i.e., $B_1 = \rho B_2$. We plot the performances for $E_{max} = 4$ mJ, $\rho = 1.6$ and $P_{avg} = 1$ mJ/s with varying B_2 in Fig. 10. We observe the increase in the average

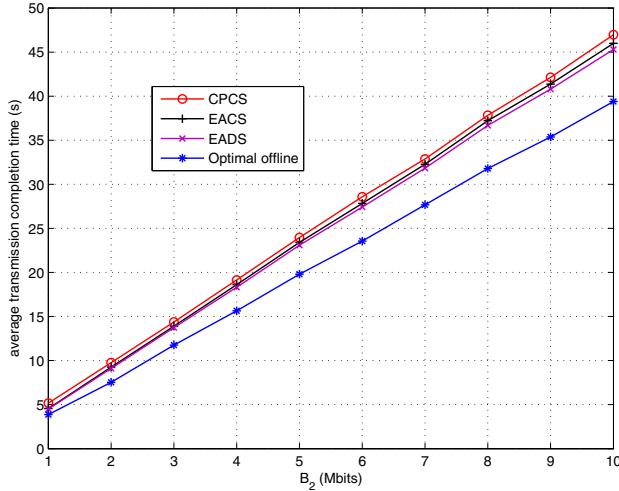

Fig. 10. Average transmission completion time versus B_2 when $\rho = 1.6$, $P_{avg} = 1$ mJ/s and $E_{max} = 4$ mJ.

transmission completion times of the policies with the number of bits. It is notable that energy adaptive policies complete the transmission faster with respect to CPCS policy. We also observe that EADS yields smaller transmission completion time on average compared to EACS; therefore, dynamically varying the power shares of the users yields better performance compared to keeping the power shares constant. Next, we plot the average transmission completion time with respect to the average recharge rate for $B_1 = 8$ Mbits, $B_2 = 5$ Mbits and $E_{max} = 10$ mJ in Fig. 11. We observe that in the small recharge rate regime, CPCS performs worse while it performs better in the high recharge rate regime compared to energy adaptive schemes. In both plots, we observe that offline knowledge of the energy arrivals yields a significant performance gain with respect to the other policies.

VI. CONCLUSION

We considered the transmission completion time minimization problem in an M -user broadcast channel where the transmitter harvests energy from nature and saves it in a battery of finite storage capacity. We characterized the structural properties of the optimal policy by means of the dual problem of maximizing the weighted sum of bits served for each user by a fixed deadline. We found that the total power allocation is the same as the single-user power allocation, which is found by the directional water-filling algorithm. Moreover, there exist $M-1$ cut-off power levels that determine the power shares of the users throughout the transmission. This structure enabled us to develop an optimal offline algorithm which uses directional water-filling iteratively.

APPENDIX A PROOF OF LEMMA 2

For $M = 2$ and given P_i , the problem in (13) is a single variable optimization problem and it has a unique solution α_i^* . We define a function $\alpha^*(P) : \mathbf{R}^+ \rightarrow [0, 1]$ which denotes the solution of the problem in (13) for $P_i = P$. Using the

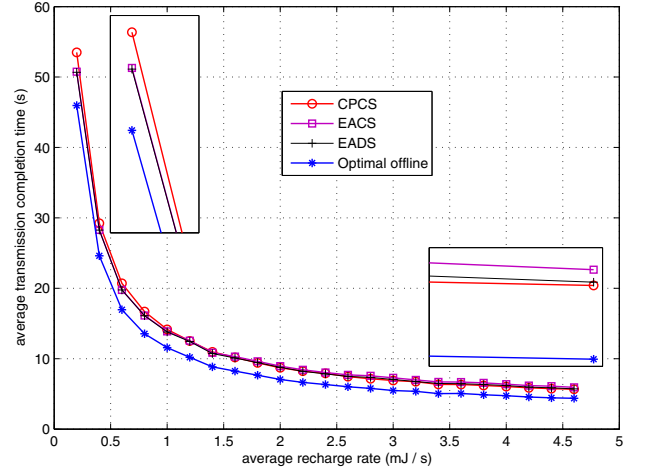

Fig. 11. Average transmission completion time versus average recharge rate when $B_1 = 8$ Mbits, $B_2 = 5$ Mbits and $E_{max} = 10$ mJ.

derivative of the objective function in (13) with respect to α for fixed P , we obtain $\alpha^*(P)$ as follows: If $\frac{\mu_2}{\mu_1} \leq 1$ then $\alpha^*(P) = 1$ for all P . If $\frac{\mu_2}{\mu_1} \geq \frac{\sigma_2^2}{\sigma_1^2}$, then $\alpha^*(P) = 0$ for all P . For $1 < \frac{\mu_2}{\mu_1} < \frac{\sigma_2^2}{\sigma_1^2}$, we have

$$\alpha^*(P) = \begin{cases} 1, & 0 \leq P \leq \frac{\mu_1 \sigma_2^2 - \mu_2 \sigma_1^2}{\mu_2 - \mu_1} \\ \frac{1}{P} \frac{\mu_1 \sigma_2^2 - \mu_2 \sigma_1^2}{\mu_2 - \mu_1}, & P \geq \frac{\mu_1 \sigma_2^2 - \mu_2 \sigma_1^2}{\mu_2 - \mu_1} \end{cases} \quad (28)$$

In the extreme cases, the lemma trivially holds. When $\frac{\mu_2}{\mu_1} < 1$, we have $\alpha^*(P) = 1$ and when $\frac{\mu_2}{\mu_1} > \frac{\sigma_2^2}{\sigma_1^2}$, we have $\alpha^*(P) = 0$ for all P . Consequently, in these extreme cases, all the power is allocated for either user 1 or user 2 and no data is transmitted for the other user. As the single-user rate-power relation is logarithmic, which is strictly concave, the lemma holds.

Now, we consider the range $1 < \frac{\mu_2}{\mu_1} < \frac{\sigma_2^2}{\sigma_1^2}$. From (28), for $0 \leq P \leq \frac{\mu_1 \sigma_2^2 - \mu_2 \sigma_1^2}{\mu_2 - \mu_1}$, we have

$$f(P) = \frac{\mu_1}{2} \log_2 \left(1 + \frac{P}{\sigma_1^2} \right) \quad (29)$$

Therefore, $f(P)$ is strictly concave in this range with the strict monotone decreasing derivative

$$\frac{df(P)}{dP} = \frac{\mu_1}{2 \ln(2)(\sigma_1^2 + P)}, \quad 0 \leq P \leq \frac{\mu_1 \sigma_2^2 - \mu_2 \sigma_1^2}{\mu_2 - \mu_1} \quad (30)$$

Using the expression of $\alpha^*(P)$ for the range $P \geq \frac{\mu_1 \sigma_2^2 - \mu_2 \sigma_1^2}{\mu_2 - \mu_1}$, $f(P)$ in this range becomes

$$f(P) = \frac{\mu_1}{2} \log_2 \left(\frac{\mu_1 (\sigma_2^2 - \sigma_1^2)}{\sigma_1^2 (\mu_2 - \mu_1)} \right) + \frac{\mu_2}{2} \log_2 \left(\frac{\mu_2 - \mu_1}{\mu_2 (\sigma_2^2 - \sigma_1^2)} (P + \sigma_2^2) \right) \quad (31)$$

$f(P)$ is strictly concave in this range, as well. The derivative

in this range is

$$\frac{df(P)}{dP} = \frac{\mu_2}{2 \ln(2)(P + \sigma_2^2)}, \quad P \geq \frac{\mu_1 \sigma_2^2 - \mu_2 \sigma_1^2}{\mu_2 - \mu_1} \quad (32)$$

Note that $\frac{df(P)}{dP}$ in different ranges in (30) and (32) are continuous and monotone decreasing. Evaluating the derivatives in (30) and (32) at $P = \frac{\mu_1 \sigma_2^2 - \mu_2 \sigma_1^2}{\mu_2 - \mu_1}$, we observe that $\frac{df(P)}{dP}$ is continuous at this point and for all P . Therefore, $f(P)$ is strictly concave for all P and its derivative is continuous everywhere in the non-negative real line for any $\mu_1, \mu_2 \geq 0$.

For the general M -user case, whenever $\mu_j \leq \mu_l$ for any $1 \leq l < j \leq M$, i.e., whenever a degraded user has a smaller coefficient, that user is allocated no power for any value of P , i.e., $\alpha_j^* = 0$ for such users. Note that for $1 \leq l < j \leq M$, if user l achieves R_l and user j achieves R_j , then user l can achieve $R_l + R_j$ [19]. Since $\mu_j < \mu_l$, we have $\mu_l R_l + \mu_j R_j < \mu_l (R_l + R_j)$, i.e., allocating all available rate to user l yields a larger weighted sum of rates. Hence, we remove user j whenever $\mu_j \leq \mu_l$ for any $1 \leq l < j \leq M$. The remaining $R \leq M$ users are such that $\sigma_1^2 \leq \sigma_2^2 \leq \dots \leq \sigma_R^2$ with $\mu_1 < \mu_2 < \dots < \mu_R$. One can show using a first order differential analysis (see also [9]) that for given P , $f(P) = \mu_1 r_1^*(P) + \dots + \mu_M r_M^*(P)$ where

$$r_1^*(P) = \frac{1}{2} \log \left(1 + \frac{\min\{P, P_{c1}\}}{\sigma_1^2} \right) \quad (33)$$

$$r_2^*(P) = \frac{1}{2} \log \left(1 + \frac{\min\{(P - P_{c1})^+, P_{c2} - P_{c1}\}}{P_{c1} + \sigma_2^2} \right) \quad (34)$$

⋮

$$r_R^*(P) = \frac{1}{2} \log \left(1 + \frac{(P - P_{c(R-1)})^+}{P_{c(R-1)} + \sigma_R^2} \right) \quad (35)$$

and where the cut-off power levels satisfy [9, Appendix B]

$$P_{cm} = \max \left\{ \left(\frac{\mu_m \sigma_{\bar{m}}^2 - \mu_{\bar{m}} \sigma_m^2}{\mu_{\bar{m}} - \mu_m} \right)^+, P_{c(m-1)} \right\} \quad (36)$$

for $m = 1, \dots, R-1$ and \bar{m} is the smallest user index with $P_{c\bar{m}} > P_{cm}$. By convention, $P_{c0} = 0$, $P_{cR} = \infty$. Note that $P_{c0} \leq P_{c1} \leq \dots \leq P_{c(R-1)} \leq P_{cR}$. As $r_m(P)$ is continuous and differentiable, so is $f(P)$. Taking the first derivative of $f(P)$ with respect to P , we have

$$\frac{df(P)}{dP} = \begin{cases} \frac{\mu_1}{2 \ln(2)(P + \sigma_1^2)}, & P \leq P_{c1} \\ \frac{\mu_2}{2 \ln(2)(P + \sigma_2^2)}, & P_{c1} < P \leq P_{c2} \\ \vdots & \vdots \\ \frac{\mu_R}{2 \ln(2)(P + \sigma_R^2)}, & P_{c(R-1)} < P \end{cases} \quad (37)$$

As in the two-user case, we observe that $\frac{df(P)}{dP}$ is continuous and monotone decreasing in each disjoint interval $(P_{c(m-1)}, P_{cm})$. Evaluating $\frac{df(P)}{dP}$ in (37) at $P = P_{cm}$, and using the expression for P_{cm} in (36), we observe that $\frac{df(P)}{dP}$ is continuous at these points and hence for all P , and $\frac{df(P)}{dP}$ is monotone decreasing. Consequently, $f(P)$ is strictly concave for all P , for any $\mu_1, \dots, \mu_M \geq 0$.

APPENDIX B PROOF OF LEMMA 3

We write the Lagrangian function as:

$$\mathcal{L} = \sum_{i=1}^{K+1} f(P_i) \ell_i - \sum_{k=1}^{K+1} \lambda_k \left(\sum_{i=1}^k P_i \ell_i - \sum_{i=0}^{k-1} E_i \right) - \sum_{k=1}^K \eta_k \left(\left(\sum_{i=0}^k E_i - E_{max} \right)^+ - \sum_{i=1}^k P_i \ell_i \right) \quad (38)$$

Note that $P_i > 0$, for all i , therefore in the Lagrangian we do not include slackness variables for P_i . Taking the derivatives of \mathcal{L} in (38) with respect to P_i , and setting them to zero, we have

$$\frac{df(P_i)}{dP_i} = \sum_{k=i}^{K+1} \lambda_k - \sum_{k=i}^K \eta_k, \quad i = 1, \dots, K+1 \quad (39)$$

Additional complimentary slackness conditions are

$$\lambda_k \left(\sum_{i=1}^k P_i \ell_i - \sum_{i=0}^{k-1} E_i \right) = 0, \quad k = 1, \dots, K \quad (40)$$

$$\eta_k \left(\left(\sum_{i=0}^k E_i - E_{max} \right)^+ - \sum_{i=1}^k P_i \ell_i \right) = 0, \quad k = 1, \dots, K \quad (41)$$

The optimal total power sequence P_i^* is the solution of (39) with the complimentary slackness conditions in (40), (41) and with the equality condition that no energy is left unused in the battery at time T . The Lagrangian multipliers λ_k and η_k are unique as the objective function in (15) is strictly concave and the constraint set is convex.

From the KKT optimality conditions in (39), we have

$$P_i = \left(\frac{df}{dP_i} \right)^{-1} \left(\sum_{k=i}^{K+1} \lambda_k - \sum_{k=i}^K \eta_k \right) \quad (42)$$

Since the derivative of $\frac{df}{dP}$ is strictly monotonically decreasing and continuous by Lemma 2, it has a well-defined inverse, which is also strictly monotonically decreasing and continuous. The Lagrange multipliers λ_i and η_i are uniquely determined by the complimentary slackness conditions as well as the following equality condition: $\sum_{i=1}^{K+1} P_i \ell_i = \sum_{i=0}^K E_i$. Therefore, the optimum total power allocation is unique.

We have $\lambda_i = 0$ and $\eta_i = 0$, if the energy causality constraint and the no-energy-overflow constraint are satisfied with strict inequality, respectively. Whenever a no-energy-overflow constraint is satisfied with equality, i.e., $\eta_i > 0$, a strict decrease in P_i^* is observed in view of (42). This is due to the fact that the inverse mapping of the derivative is monotonically decreasing and the argument of the inverse in (42) is also decreasing. Similarly, whenever an energy causality constraint is satisfied with equality, i.e., $\lambda_i > 0$, a strict increase in P_i^* is observed in view of (42). Thus, equality of energy causality constraints leads to an increase while that of no-energy-overflow constraint leads to a decrease in the total power. Imposing the energy constraint at time T as an equality, we get exactly the optimal power allocation

policy in the single-user E_{max} constrained average throughput maximization problem in [7], [8], i.e., in the special case of $\mu_1 > 0$ and $\mu_m = 0$, for $m = 2, \dots, M$. Moreover, this characterization is the same for any $\mu_1, \dots, \mu_M \geq 0$ because the strict concavity of $f(P)$ in Lemma 2 holds for any $\mu_1, \dots, \mu_M \geq 0$.

REFERENCES

- [1] M. Gatzianas, L. Georgiadis, and L. Tassiulas, "Control of wireless networks with rechargeable batteries," *IEEE Trans. Wireless Commun.*, vol. 9, pp. 581–593, Feb. 2010.
- [2] V. Sharma, U. Mukherji, and V. Joseph, "Efficient energy management policies for networks with energy harvesting sensor nodes," in *2008 Allerton Conference*.
- [3] V. Sharma, U. Mukherji, V. Joseph, and S. Gupta, "Optimal energy management policies for energy harvesting sensor nodes," *IEEE Trans. Wireless Commun.*, vol. 9, pp. 1326–1336, Apr. 2010.
- [4] J. Lei, R. Yates, and L. Greenstein, "A generic model for optimizing single-hop transmission policy of replenishable sensors," *IEEE Trans. Wireless Commun.*, vol. 8, pp. 547–551, Feb. 2009.
- [5] J. Yang and S. Ulukus, "Transmission completion time minimization in an energy harvesting system," in *2010 CISS*.
- [6] —, "Optimal packet scheduling in an energy harvesting communication system," *IEEE Trans. Commun.*, vol. 60, pp. 220–230, Jan. 2012.
- [7] K. Tutuncuoglu and A. Yener, "Optimum transmission policies for battery limited energy harvesting systems," *IEEE Trans. Wireless Commun.*, to appear, 2012. Also available at [arXiv:1010.6280].
- [8] O. Ozel, K. Tutuncuoglu, J. Yang, S. Ulukus, and A. Yener, "Transmission with energy harvesting nodes in fading wireless channels: optimal policies," *IEEE J. Sel. Areas Commun.*, vol. 29, pp. 1732–1743, Sep. 2011.
- [9] J. Yang, O. Ozel, and S. Ulukus, "Broadcasting with an energy harvesting rechargeable transmitter," *IEEE Trans. Wireless Commun.*, vol. 11, pp. 571–583, Feb. 2012.
- [10] M. A. Anteppli, E. Uysal-Biyikoglu, and H. Erkal, "Optimal packet scheduling on an energy harvesting broadcast link," *IEEE J. Sel. Areas Commun.*, vol. 29, pp. 1721–1731, Sep. 2011.
- [11] B. Prabhakar, E. Uysal-Biyikoglu, and A. El Gamal, "Energy-efficient transmission over a wireless link via lazy scheduling," in *2001 IEEE INFOCOM*.
- [12] E. Uysal-Biyikoglu, B. Prabhakar, and A. E. Gamal, "Energy efficient packet transmission over a wireless link," *IEEE/ACM Trans. Networking*, vol. 10, pp. 487–499, Aug. 2002.
- [13] M. Zafer and E. Modiano, "A calculus approach to energy-efficient data transmission with quality-of-service constraints," *IEEE/ACM Trans. Networking*, vol. 17, pp. 898–911, June 2009.
- [14] A. Fu, E. Modiano, and J. N. Tsitsiklis, "Optimal transmission scheduling over a fading channel with energy and deadline constraints," *IEEE Trans. Wireless Commun.*, vol. 5, pp. 630–641, Mar. 2006.
- [15] —, "Optimal energy allocation and admission control for communications satellites," *IEEE/ACM Trans. Networking*, vol. 11, pp. 488–500, June 2003.
- [16] R. Berry and R. Gallager, "Communication over fading channels with delay constraints," *IEEE Trans. Inf. Theory*, vol. 48, pp. 1135–1149, May 2002.
- [17] E. Yeh, "Minimum delay multi access communication for general packet length distributions," in *2004 Allerton Conference*.
- [18] N. Ehsan and T. Javidi, "Delay optimal transmission policy in a wireless multi-access channel," *IEEE Trans. Inf. Theory*, vol. 54, pp. 3745–3751, Aug. 2008.
- [19] T. M. Cover and J. Thomas, *Elements of Information Theory*. John Wiley and Sons Inc., 2006.
- [20] O. Ozel, J. Yang, and S. Ulukus, "Broadcasting with a battery limited energy harvesting rechargeable transmitter," in *2011 IEEE WiOpt*.

- [21] S. Boyd and L. Vandenberghe, *Convex Optimization*. Cambridge University Press, 2004.
- [22] R. L. Burden and J. D. Faires, *Numerical Analysis*. Thomson Brooks/Cole, 2005.



Omur Ozel received the B.Sc. and the M.S. degrees with honors in electrical and electronics engineering from the Middle East Technical University (METU), Ankara, Turkey, in June 2007 and July 2009, respectively. Since August 2009, he has been a graduate research assistant at the University of Maryland College Park, working towards Ph.D. degree in electrical and computer engineering. His research focuses on information and network theoretical aspects of energy harvesting communication systems. He is a graduate student member of IEEE.



particular emphasis on energy management in energy harvesting networks.

Jing Yang received the B.S. degree in electronic engineering and information science from the University of Science and Technology of China, Hefei, China in 2004, and the M.S. and Ph.D. degrees in electrical and computer engineering from the University of Maryland, College Park in 2010. Since October 2010, she has been a research associate in the department of electrical and computer engineering at the University of Wisconsin-Madison. Her research interests are in learning, inference, optimization, and scheduling in complex networks, with



Sennur Ulukus is a Professor of Electrical and Computer Engineering at the University of Maryland at College Park, where she also holds a joint appointment with the Institute for Systems Research (ISR). Prior to joining UMD, she was a Senior Technical Staff Member at AT&T Labs-Research. She received her Ph.D. degree in Electrical and Computer Engineering from Wireless Information Network Laboratory (WINLAB), Rutgers University, and B.S. and M.S. degrees in Electrical and Electronics Engineering from Bilkent University.

Her research interests are in wireless communication theory and networking, network information theory for wireless communications, signal processing for wireless communications, information-theoretic physical-layer security, and energy-harvesting communications.

Dr. Ulukus received the 2003 IEEE Marconi Prize Paper Award in Wireless Communications, the 2005 NSF CAREER Award, and the 2010–2011 ISR Outstanding Systems Engineering Faculty Award. She served as an Associate Editor for the IEEE TRANSACTIONS ON INFORMATION THEORY between 2007–2010, as an Associate Editor for the IEEE TRANSACTIONS ON COMMUNICATIONS between 2003–2007, as a Guest Editor for the *Journal of Communications and Networks* for the special issue on energy harvesting in wireless networks, as a Guest Editor for the IEEE TRANSACTIONS ON INFORMATION THEORY for the special issue on interference networks, as a Guest Editor for the IEEE JOURNAL ON SELECTED AREAS IN COMMUNICATIONS for the special issue on multiuser detection for advanced communication systems and networks. She served as the TPC co-chair of the Communication Theory Symposium at the 2007 IEEE Global Telecommunications Conference, the Medium Access Control (MAC) Track at the 2008 IEEE Wireless Communications and Networking Conference, the Wireless Communications Symposium at the 2010 IEEE International Conference on Communications, the 2011 Communication Theory Workshop, the Physical-Layer Security Workshop at the 2011 IEEE International Conference on Communications, the Physical-Layer Security Workshop at the 2011 IEEE Global Telecommunications Conference. She was the Secretary of the IEEE Communication Theory Technical Committee (CTTC) in 2007–2009.